

# The Mass Defect Nature of Gravity

Thomas Neudorfer Lockyer  
1611 Fallen Leaf Lane, Los Altos, CA 94024  
e-mail: [tnlockyer@aol.com](mailto:tnlockyer@aol.com)

A gravity theory must explain why mass is attracted to mass. Three hundred years after Newton's formulation and one hundred years after Einstein's special relativity calculation, we have been no closer to understanding the cause for the force of gravity. A case is now made for the well known atomic mass defect as the mass sink that forces mass to be attracted to mass. Theory by Dr. T Van Flandern and experiments by Dr. E. Podkletnov are discussed that serve to support the nature and superluminal velocity of the gravity force.

## 1. Introduction

It has been over three hundred years since Newton (1642-1727) first developed the mathematics describing gravity. The mathematics for the constant of gravity  $G$  was published in Newton's law of universal gravitation on 5 July 1687. Newton did not claim to understand the cause of gravity.

About 100 years ago (1916), Einstein (1879-1955) published his "The foundation for the general theory of relativity" describing an astronomical theory on gravity, which was based on a highly speculative curvature of space supposedly caused by the presence of matter, over astronomical distances at relativistic velocities.

But, Einstein's gravity theory was not without critics. One prominent critic was Nikola Tesla, who stated, quote, "I hold that space cannot be curved, for the simple reason that it can have no properties. To say that in the presence of large bodies, space becomes curved is equivalent to saying that something can act on nothing. I for one refuse to subscribe to such a view".

Many modern theorists also reject the idea that all space consists of some sort of ether "stuff", so most agree with Tesla.

## 2. The Present State of Science

The last 84 years have seen many advances in the understanding of nature. The neutron was verified by Chadwick in 1932. In 1934, Chadwick and Goldhaber determined that the deuteron (proton bound to neutron) binding energy (mass defect) holding the proton to neutron together was between 2.62 MeV and 1.8 MeV.

We now have much improved details about the structure of atomic nuclei [1], and with this new knowledge, a reason for the seemingly perverse force of mass attracting mass, can be suggested. We may now solve the mystery of the exclusive attractive force of gravity.

## 3. Atomic Mass Defects

It is now known that when nucleons (protons and neutrons) bind to each other, atomic energy is released that makes the atom weigh less than the mass of those same individual nucleons. This missing mass (energy) equals about 1 percent of the mass of the atom.

The missing mass is called a mass "defect". It is the mass defect that holds the nucleons together by the strong force. If one replaces the missing mass (energy) the nucleons unbind. This

suggests that the atomic mass defects act as a mass (energy) sink as the cause for the force of gravity between masses.

## 4. Large Mass Defects (Holes) in Astronomical Bodies

The mass of the earth is estimated as  $5.97223 \times 10^{24}$  kg. At about 1 percent, the mass defect of the earth is a substantial  $5.4497 \times 10^{22}$  kg, a very large missing mass indeed. The earth mass defect is about 2/3 of the mass of the moon, to show the scale of the earth's missing mass defect.

## 5. Proposed Nature of Gravity

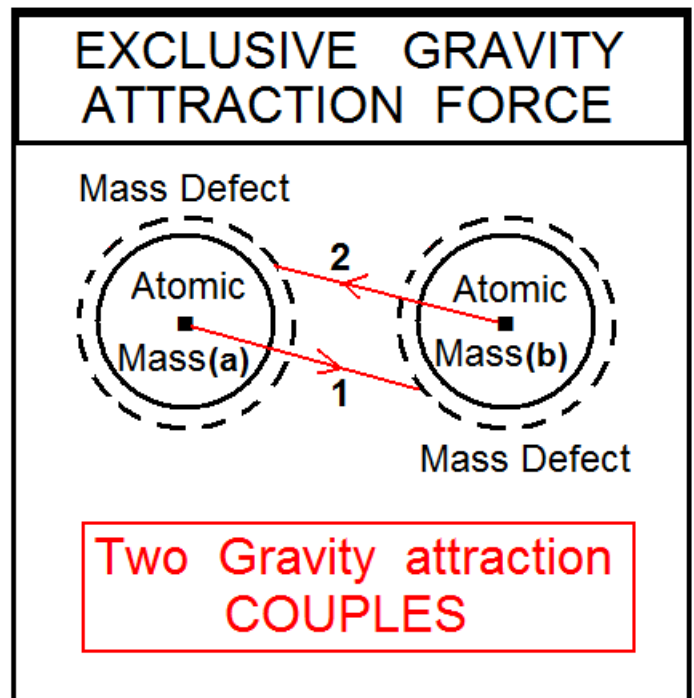

Fig. 1. Shown are the two couples that constitute the force of gravity. Atomic (mass energy) is attracted to the mass defect for each atom.

The cause of gravity is seen as the mass (energy) of one atomic substance seeking to replace the missing mass (energy) of another atomic substance. We see in Fig. 1 that this results in two couples of equal force. Newton simply doubled the value of the gravity Constant  $G$ , based on just one of the two equal couples, for simplicity. The use of the factor of two times the single couple would not have worked if the two way couples

were of different forces. Eq. (1) reviews the constants associated with Newton's equation for the force of gravity on earth, to six significant figures [2]. The standard CODATA values published by NIST for other fundamental constants used in this paper are given in Eq. (2) [2].

$$\begin{aligned} G &= 6.67428 \times 10^{-11} \text{ m}^3/\text{kg}\cdot\text{s}^2 && \text{Newton Gravity constant} \\ m_e &= 5.97223 \times 10^{24} \text{ kg} && \text{Mass of the earth} \\ R_e &= 6.37544 \times 10^6 \text{ m} && \text{Radius of the earth} \\ g &= G \frac{M_e}{R_e^2} = 9.80665 \text{ m/s}^2 && \text{Acceleration of gravity} \end{aligned} \quad (1)$$

$$\begin{aligned} e &= 1.60217649 \times 10^{-19} \text{ C} && \text{Charge constant} \\ h &= 6.62606896 \times 10^{-34} \text{ J}\cdot\text{s} && \text{Planck constant} \\ c^2 &= 8.98755179 \times 10^{16} \text{ m}^2/\text{s}^2 && \text{Velocity of light squared} \\ m_{amu} &= 1.66053878 \times 10^{-27} \text{ kg} && \text{Atomic mass constant} \\ \mu_e &= -9.28476377 \times 10^{-24} \text{ A}\cdot\text{m}^2 && \text{Electron magnetic moment} \\ \epsilon_0 &= 8.85418782 \times 10^{-12} \text{ F/m} && \text{Electric constant} \end{aligned} \quad (2)$$

The value of  $g$  is an average taken from many locations by international standards organizations. From this average, the mass of the earth  $m_e$  and the radius of the earth  $R_e$  are mathematically estimated using the universal gravity constant  $G$  value. The value for  $G$  can be obtained by the Cavendish balance or similar device.

## 6. A New $G$ Value $G_p$ for Mass Defect Force of Gravity

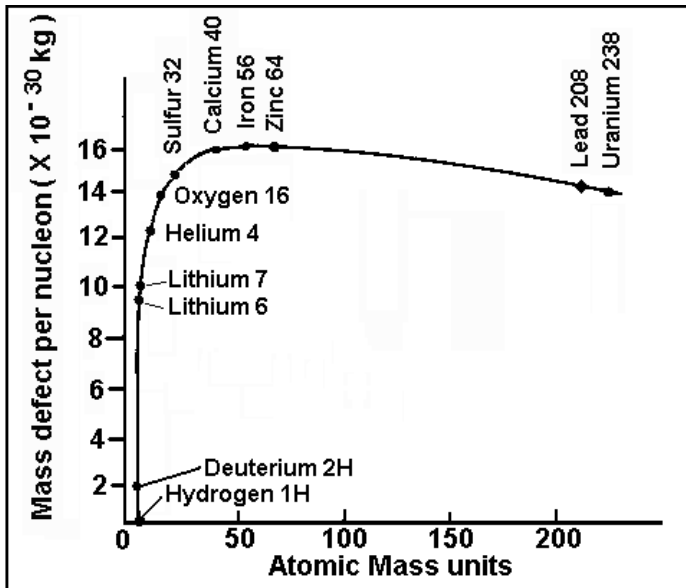

Fig. 2. Graph of binding energy per nucleon of the elements. We see that Sulfur 32 has a compromise average mass defect value.

Fig. 2 graphs the measured binding energy per atom. The earth and all other matter in the universe is composed of atomic matter. The atomic nuclei are bound combinations of protons and neutrons with a mass defect (sink) due to the release of atomic binding energy, as the atoms are formed. The atom thus can be considered both a source and a sink for mass (energy). The mass sink will now be considered as the cause, for the exclu-

sive attractive force of gravity. Nature abhors the unbalance of the missing  $\sim 1$  percent of the atomic masses. This missing mass defect equals approximately the same value for the heavy elements, but the atoms with a few nucleons, like Helium or Lithium have smaller mass defects. (Fig. 2)

The mass defect of Sulfur 32 will now be derived as an effective average mass defect factor  $d_S$ . This value will serve to derive a new universal gravity constant  $G_p$  to replace the old universal Newton  $G$ .

In Eq. (3), the published Sulfur binding energy  $E_{SA}$  in electron volts is converted to Joule (J) by multiplying with the fundamental charge  $e$ . The Sulfur 32 atom (published) binding energy, in electron volts, is converted to mass so the percentage of missing mass binding energy mass defect  $d_S$  is obtained for general use as an average for calculating the force of gravity.

$$\begin{aligned} E_{SA} &= 271.760656 \text{ MeV} = 4.35408533 \times 10^{-11} \text{ J} \\ m_{SA} &= \frac{E_{SA}}{c^2} = 4.84457329 \times 10^{-28} \text{ kg} \\ m_S &= 31.972070 m_{amu} = 5.3090862 \times 10^{-26} \text{ kg} \\ d_S &= \frac{m_{SA}}{m_S} = 9.1250605 \times 10^{-3} \end{aligned} \quad (3)$$

This Sulfur 32 binding energy in Joule  $E_{SA}$  is then converted into mass  $m_{SA}$  by dividing by the velocity of light  $c$  squared. The Sulfur 32 mass in atomic mass number 31.972070 is converted into mass  $m_S$  in kilograms (kg) by multiplying by the published atomic mass unit  $m_{amu}$ . By then dividing the Sulfur mass  $m_S$  into the Sulfur mass defect  $m_{SA}$  in kilograms (kg) one obtains the dimensionless general mass defect factor  $d_S$ .

The general mass defect factor  $d_S$  can then be used as an average value for determining the mass defect in astronomical bodies, like the earth.

Using the value for the average mass defect  $d_S$ , the new gravity constant  $G_p$  is derived, Eq. (4) based on the published Newton gravity constant  $G$ . This derived value, for the universal gravity constant  $G_p$  then has the factor of two buried in its value, from the original  $G$ .

$$G_p = \frac{G}{d_S} = 7.31423 \times 10^{-9} \text{ m}^3/\text{kg}\cdot\text{s}^2 \quad (4)$$

The new gravity constant  $G_p$  is to replace the old Newton gravity constant  $G$  in all future calculations for the attractive force of gravity. The attraction of gravity between masses is theorized to be caused by a mass defect in at least one of the masses.

## 7. Review of Gravity Constants

The new mass defect gravity constant  $G_p$  must be equivalent to the Newton constant  $G$  as proof of concepts. The earth mass defect  $m_B = d_S \cdot m_e = 5.44969600 \times 10^{22} \text{ kg}$  would attract a one kilogram test mass  $m_X = 1 \text{ kg}$  as one couple, and the other system couple would then be a one kilogram test mass defect of  $m_{XD} = d_S \cdot m_X = 9.1250605 \times 10^{-3} \text{ kg}$ , times the earth's mass

$m_e = 5.97223 \times 10^{24}$  kg. The two couples are identical forces, as demonstrated. Ordinarily we don't think that a body attracts the earth with an equal force to the earth attracting the same body.

This result demonstrates the equality, regardless of the disparity of the attracting masses. We see that  $G_p$ , the newly derived mass defect gravity constant, can combine the two equal gravity couples, without loss of precision.

This previously unknown fact of the two gravity couples being (numerically) equal has escaped Newton and Einstein. The fact that attracting masses have equal mutual forces has made their calculations correct, by their use of the factor of two.

## 8. Photons and Gravity Forces

Gravity will attract pure energy (the photon) as was demonstrated by the Pound and Rebka experiment [3]. Pound and Rebka used radioactive Fe57, 14.4 KeV photons in a sensitive Mossbauer effect to measure photon frequency  $f$  change (hence  $E = hf$ ) by photons moving up  $H = 20$  m against gravity. Eq. (5) gives a mathematical analysis of the typical Pound and Rebka experimental results.  $m_{ph}$  is the relativistic photon mass based on the photon energy, used to obtain the gravitational potential energy  $E_{GP}$  that is lost by the photon over the 20 meters, against the force of gravity. The photon's frequency change  $f_{GP}$  is the value, measured by the Mossbauer effect which gives the photon  $E_{GP}$  gravitational potential energy in Joule when multiplied by the Planck constant  $h$ , as expected. The amount of photon energy loss  $E_{GP}$  over  $H$  is then Planck constant  $h$  times  $f_{GP}$  or finally  $E_{GP}$ .

$$\begin{aligned} E_{ph} &= 14.4 \text{ keV} = 2.30713414 \times 10^{-15} \text{ J} \\ m_{ph} &= \frac{E_{ph}}{c^2} = 2.56703293 \times 10^{-32} \text{ kg} \\ H &= 20 \text{ m} \\ E_{GP} &= m_{ph}gH = 5.03479870 \times 10^{-30} \text{ J} \\ f_{GP} &= \frac{E_{GP}}{h} = 7.59847012 \times 10^3 \text{ Hz} \\ f_{ph} &= \frac{E_{ph}}{h} = 3.48190481 \times 10^{18} \text{ Hz} \\ r &= \frac{f_{GP}}{f_{ph}} = \frac{E_{GP}}{E_{ph}} = \frac{gH}{c^2} = 2.18227393 \times 10^{-15} \end{aligned} \quad (5)$$

We now will show that the mass defect gravity constant gives EQUIVALENT energy lost by a photon against a gravity head of 20 meters, Eq. (6).

$$\begin{aligned} G_p m_B &= G m_e \\ F_{ph} &= G_p \frac{m_B m_{ph}}{R_e^2} = m_{ph} g = 2.51739934988 \times 10^{-31} \text{ N} \\ E_{GP} &= F_{ph} H = 5.0347987 \times 10^{-30} \text{ J} \end{aligned} \quad (6)$$

$E_{GP}$  is proof of equivalence of mass defect as the source for the force of gravity.

Eq. (6) show that the photon energy  $E_{GP}$  is attracted to the mass defect of the earth  $m_B$ , not the earth's mass  $m_e$  as was assumed by the old Newton  $G$ . The photon is attracted to the

earth's mass defect  $m_B$ . The new mass defect  $G_p$  gravity constant thus proves to be a physically justified gravity constant.

The energy  $E_{ph}$  of the starting photon is the  $f_{ph}$  times  $h$  and equals the starting photon energy  $E_{ph} = 2.30713414 \times 10^{-15}$  J.

## 9. Gravity Measurements with Mass Balance

Lately the Newton gravity constant has almost exclusively been measured by the attraction force between two small masses, in a torsion balance. A torsion balance test can be shown to give equivalent values using either the Newton  $G$  or the mass defect  $G_p$  as universal constants, as expected.

The mass defect gravitational constant  $G_p$  provides a physically defensible explanation for the force of gravity. In retrospect, it would be impossible, physically, for a mass to attract a mass, because they are alike. Past theories tried to use mediators, like the unprecedented gravitons, supposedly acting like photons which are the transmitters of the electromagnetic force. But the idea of gravitons just replaces one mystery with a more complex and intractable one. The question then becomes, what causes the gravitons to be continually radiated from a mass, and what do gravitons do when they encounter an alien mass to cause the masses to be attracted. And how would gravitons explain the two equal couples between attracting masses?

The use of known measurable mass defects, built into every atom, requires no such mysterious graviton as a source for the force of gravity.

## 10. Lithium 7 Mass Defect Gravity Attraction

The mass defect for Lithium 7 is calculated in Eq. (7). Lithium 7 is chosen from the graph of Fig 2. Lithium 7 is the most abundantly isotope of Lithium, and has a smaller mass defect per the number of nucleons than the average atom. The Lithium 7 mass defect factor  $d_{Li}$  in Eq. (7) is smaller than the general Sulfur derived mass defect factor  $d_S$  and should provide a means to prove the smaller Lithium mass defect is a source for the reduced force of gravity, using a torsion balance.

$$\begin{aligned} E_{LiA} &= 39.244526 \text{ MeV} = 6.9959716 \times 10^{-12} \text{ J} \\ m_{LiA} &= \frac{E_{LiA}}{c^2} = 6.9959716 \times 10^{-29} \text{ kg} \\ m_{Li} &= 7.016003 m_{amu} = 1.165035 \times 10^{-29} \text{ kg} \\ d_{Li} &= \frac{m_{LiA}}{m_{Li}} = 6.0049479441 \times 10^{-3} \end{aligned} \quad (7)$$

Using Lithium 7 for ALL torsion balance masses should indicate (experimentally) that the force of gravity is related to the atomic mass defects. The mass balance should show a marked difference between Sulfur 32 and Lithium 7 test masses.

The literature has yielded an experimenter, Gyula. I. Szasz, [4], who apparently has detected a difference between gravitational mass and inertial mass. A drop experiment used elements Li, Be, B, C, Al, Fe and Pb, from a height of 110 meters in a vacuum. The experiment was performed in the drop tower of the University of Bremen. A stop action photograph, taken after a drop time of 4.6 seconds, is shown in Fig. 3. Note the Lithium shows a marked difference. At 4.6 seconds drop time the car-



riage has traveled 103.754357 meters. The Lithium sample about 0.08 meters less at 103.674357 meters. The acceleration is 9.79908 m/s<sup>2</sup> versus 9.80665 m/s<sup>2</sup> average value. This difference prompted Szasz to conclude that acceleration depends on the composition of the test bodies.

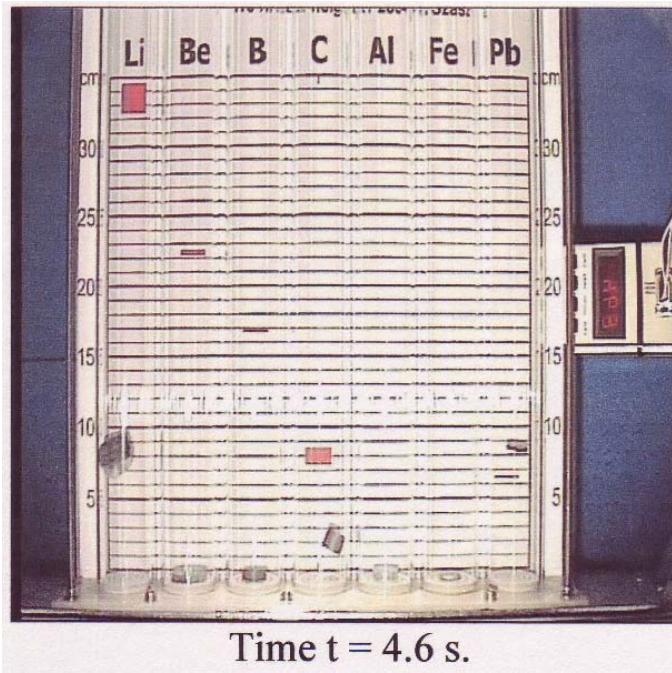

Fig. 3. The Lithium (Li) sample shows a marked difference in acceleration at 4.6 seconds drop time in the 110m vacuum tower at Bremen.

### 11. Instantaneous Gravity Speed

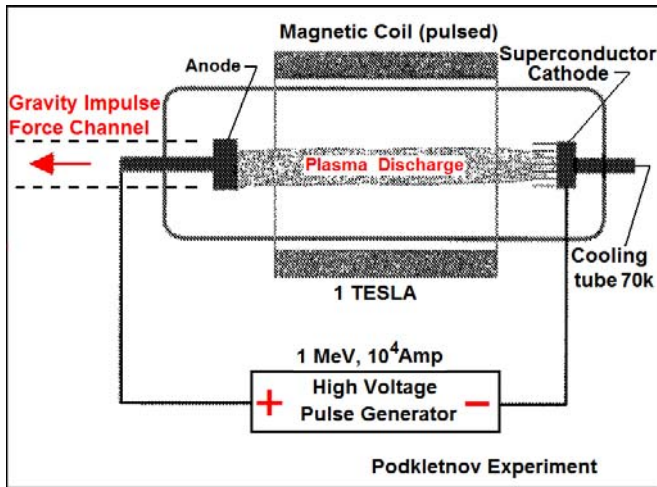

Fig. 4. Podkletnov gravity pulse experimental setup. The HTSC cathode is cooled by a tube with liquid nitrogen. The 1 TESLA electromagnetic field coil is pulsed during discharge of the high voltage pulse generator. The tube discharge current has been estimated as at least 10<sup>4</sup> Ampere. The gravity beam column apparently (impulse) travels at many times the velocity of electromagnetic radiation, in unpublished experiments.

The velocity of the photon *c* is the same in all frames of reference, as was postulated by Lorentz-Fitzgerald-Einstein. The photon generates its own motion [1, pp. 66-68], thus giving light a constant effective velocity of *c*.

The American Astronomer Thomas Van Flandern (1940-2009) [5] logically argues that gravity acts at many times the velocity of light across astronomical distance. Gravity at the speed of light, is argued, would produce a couple that would add torque to orbiting masses.

Recent experiments performed by Dr. Eugene Podkletnov and co-workers used the impulse apparatus as shown in Fig. 4.

In Fig. 4 Podkletnov [6] detected an anomalous impulse force beam. The beam gave an unexpected physical reaction on masses independently of their compositions. Pendulums set a various distances (6 meters to 150 meters) shielded from the source by a brick wall, showed no measurable loss in energy of the gravity beam. The gravity impulse also was apparently shown, with atomic clock detectors, to travel at least 64 times the velocity of light in unpublished experiments at distances of about 1 Kilometer. Podkletnov explains the experiment using atomic clocks, in a (YouTube interview) [7].

Work by many experimenters has verified the use of HTSC superconductors to obtain anomalous gravity effects. Recently, Claude Poher, Toulouse (FR) obtained a United States Patent Application, US 2010/0251717 Oct. 7, 2010. Poher has a YouTube demonstration [8].

### 12. Speculations on Anomalous Impulse Force Beam

The anomalous beam developed by Podkletnov, which apparently has a velocity of at least 64 times the velocity of light, uses the Cooper pairs in the HTSC superconductive cathode.

The Coulomb product  $k_e e^2 = e^2 / 4\pi\epsilon_0 = 2.30707713 \times 10^{-28}$  J-m is a universal constant determined from the quantities in Eq. (2).

The von Klitzing pair bond length is  $b_{vK} = 2|\mu_e|/ec = 3.86607074 \times 10^{-13}$  m, and the von Klitzing pair binding energy is then  $E_{vK} = k_e e^2 / b_{vK} = 5.9674984 \times 10^{-16}$  J [1, pp.182-183].

The Cooper pair bond length is  $b_C = \sqrt{2}|\mu_e|/ec = 2.7337248 \times 10^{-13}$  m, and the Cooper pair binding energy is then  $E_C = k_e e^2 / b_C = 8.4393172 \times 10^{-16}$  J [1, pp.182-183].

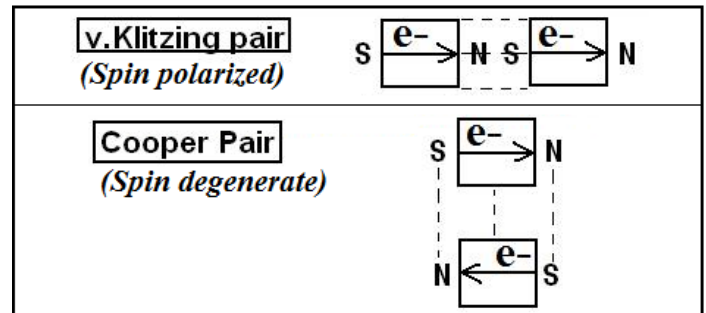

Fig. 5. The v. Klitzing electron pair binding energy only occurs a superconducting temperatures. The Cooper electron pair occurs at superconducting temperatures, and at room temperature with high electric fields.

In [1, pp. 184-186] I have shown that Cooper and v. Klitzing electron pairing are due to the electrons superior near field magnetic moment forces. Fig. 5 shows that electrons are bound by the missing mass (binding energy) that holds the electron pairs

together. The electron pair "Binding energy times Bond length"  $k_e e^2 = e^2 / 4\pi\epsilon_0 = 2.30707713 \times 10^{-28}$  J-m holds, not only for electron pairing, but also pairing of proton to neutron, neutron to neutron and proton to proton, as a universal constant. The electron pairs are held together by the strong force, just as with the nucleons, by the releasing of the binding energy photon.

The pairing of electrons releases the binding energy and produces a mass defect in the pair. This mass defect holds the pair together until the missing (mass) energy can be replaced from the environment, in a similar effect to the unbinding of atomic nucleons. The v. Klitzing electron pair only occurs at superconducting temperatures, but the Cooper pairing can also occur with room temperatures and at high electric field strengths produced, for examples, in narrowing conductors or point contacts.

Podkletnov required high current density of Cooper pairs in the cathode, that then impulses the mass defect of the pairs as a possible source of the anomalous force field.

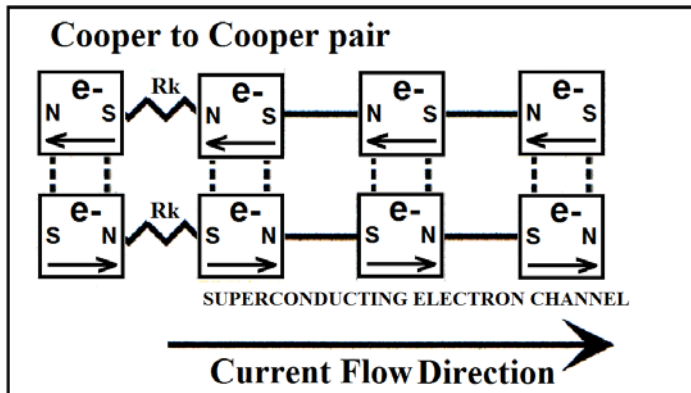

Fig. 6. The Cooper pairs bind to Cooper pairs in the HTSC superconductor cathode in a condensate at high density. The electrons have a mass defect and charges that at impulse produce the previously unknown radiation.

Fig. 6 shows the composition of a superconducting current. As the electrons form into Cooper pairs, the binding energy release gives a resistance dissipation of two von Klitzing ( $R_{vK} = h/e^2 = 25.8128076 \Omega$ ) in parallel. The pairs remain bound at low temperatures and are joined by others into a superconducting electron channel. Other similar electron channels conjoin in parallel thus forming a dense condensate. At superconducting temperatures the spin degenerate electron pairs form a super fluid of electrons, just as the spin degenerate Helium atoms have demon-

strated. The electron pair oscillating bond lengths then explain how it is possible for the superconductive currents to flow forever, if the temperature is maintained at or below 70 K.

## 12. Conclusion

It is proposed, and it has been shown that the exclusive attractive force of gravity force between masses can be attributed to the mass defect that exists in all atomic nuclei with more than two nucleons. The positive mass (energy) of a single nucleon or photon is attracted to the mass defect of atoms with two or more nucleons. The new mass defect equations produce results equivalent to the use of Newton's universal gravity constant, and provide a physically defensible cause for the exclusive attractive force of gravity.

I believe it will be possible to test the mass defect theory of gravity using Lithium 7, which has less than average binding energy mass defect, as the test masses in a torsion balance.

The force of gravity is transmitted at superluminal speeds by a new and previously unknown longitudinal couple, as indicated by arguments of Dr. T. Van Flandern and the experimental results of Dr. E. Podkletnov.

## References

- [1] T. N. Lockyer, **Fundamental Physical Constants Derived From Particle Geometric Structures** (TNL Press, 2008).
- [2] Peter J. Mohr, Barry N. Taylor, David B. Newall, "CODATA Recommended Values of the Fundamental Physical Constants: 2006", *Reviews of Modern Physics* (April 2008) <http://physics.nist.gov/cuu/Constants/codata.pdf>.
- [3] R. Pound, G. Rebka Jr., *Phys. Rev. Letters* **4**: 274 (1960).
- [4] Gyula. I. Szasz, "What Causes the Gravitation?" in **Physics of Elementary Processes** (ISBN: 9632197917, Budapest, 21, April 2006).
- [5] T. Van Flandern, **Dark Matter Missing Planets & New Comets** (North Atlantic Books, 1993).
- [6] Eugene Podkletnov "Impulse Gravity Generator Based on Charged (Y Ba2Cu3O7-y) Superconductor with Composite Structure" (30 Aug 2001), <http://xxx.lanl.gov/abs/physics/0108005>.
- [7] Eugene Podkletnov, "(3 of 5) Superconductor Research Scientists Gives Rare Interview", <http://www.youtube.com/watch?v=gRwKSUQbB7E&feature=related> (2004).
- [8] Claude Poher, "Universons - Claude Poher", <http://www.youtube.com/watch?v=ajCsSytmnLM>.